

MADE IN ITALY
 Certified Integrated Systems
 ISO 9001 • ISO 14001
 SAS 18001 • SA 8000

www.sige-spa.it info@sige-spa.it
 fax +39 071 90 90 804
 tel +39 071 90 000 r.a.
 60020 Polverigi (AN) ITALY



Per info riguardo il montaggio

La Sige Spa si riserva il diritto di apportare variazioni senza preavviso.
 Sige Spa has the right to make changes on it without notice.
 Sige Spa se le droit d'apporter des variations sans préavis.



Caratteristiche • Product • Produit

- Due Ripiani separati
Two independent shelves - Deux étagères séparés
- Ripiano con ringhiera cromata
Shelf with chrome-plated rail - Étagère avec galerie fil chromé
- 20 kg per ripiano
20 kg each shelf - 20 kg chaque étagère
- Cerniera max ingombro 25 mm
Maximum hinge protrusion from centre 25 mm - Charnière max espace 25 mm

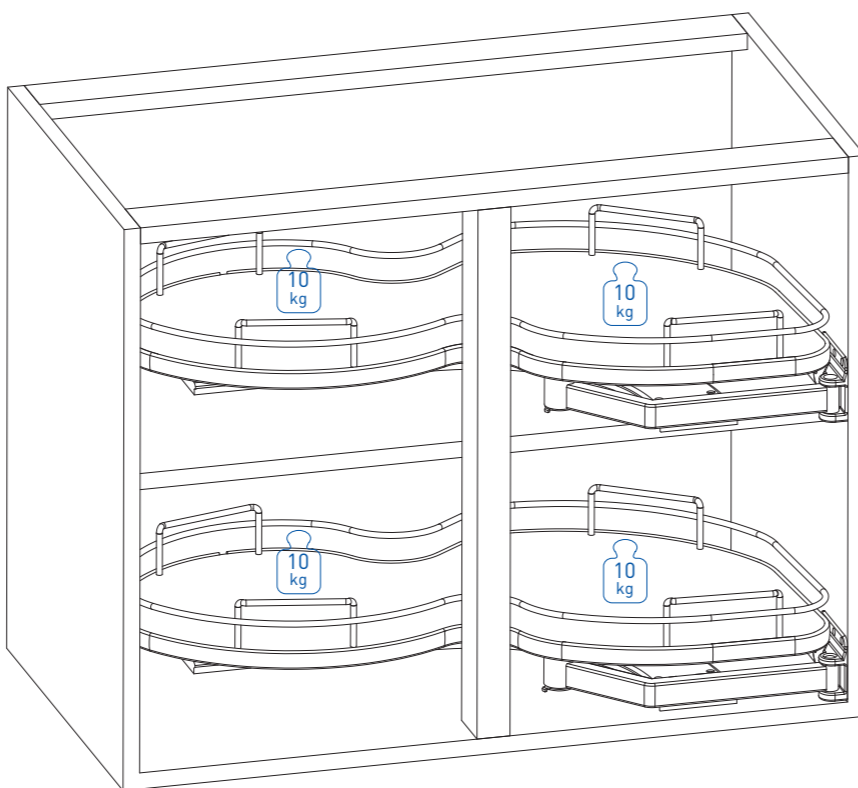

Componenti • Parts • Composants

- A. n° 2 Ripiani - Shelves - Étagères
- B. n° 2 Guide - Slides - Glissières
- C. n° 2 Meccanismi - Mechanisms - Mécanismes
- D. n° 1 Dima di montaggio - Mounting template - Modèle de montage
- E. n° 2 Sicurezza ripiano - Shelf safety ring - Anneau de sécurité étagère
- F. n° 4 Gommini fermacorsa - Rubber stopper - Caches en caoutchouc
- G. n° 2 Supporti rotanti - Pivoting guide - Soutien par support

Utensileria • Tools • Outils

Minuteria interna • Fittings • Ferrure

- n° 12 euroviti 6x14
n° 12 euroscrews 6x14
- n° 12 eurovis 6x14
n° 12 Self-tapping screws 4x25 mm
- n° 16 Viti autofilettanti 4x25 mm
n° 16 Vis auto-taraudeuses 4x25 mm

Montaggio 5 min Assembly 5 min Montage 5 min

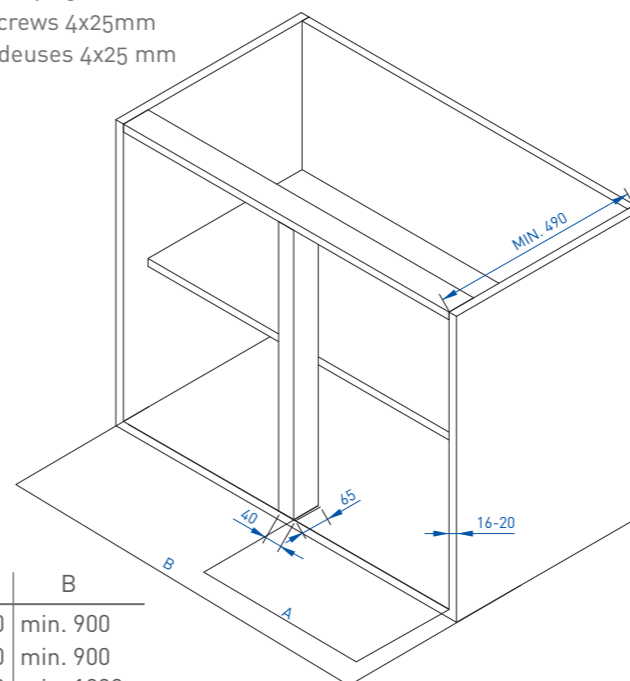

	A	B
Nuvola 45	min. 410	min. 900
Nuvola 50	min. 460	min. 900
Nuvola 60	min. 560	min. 1000

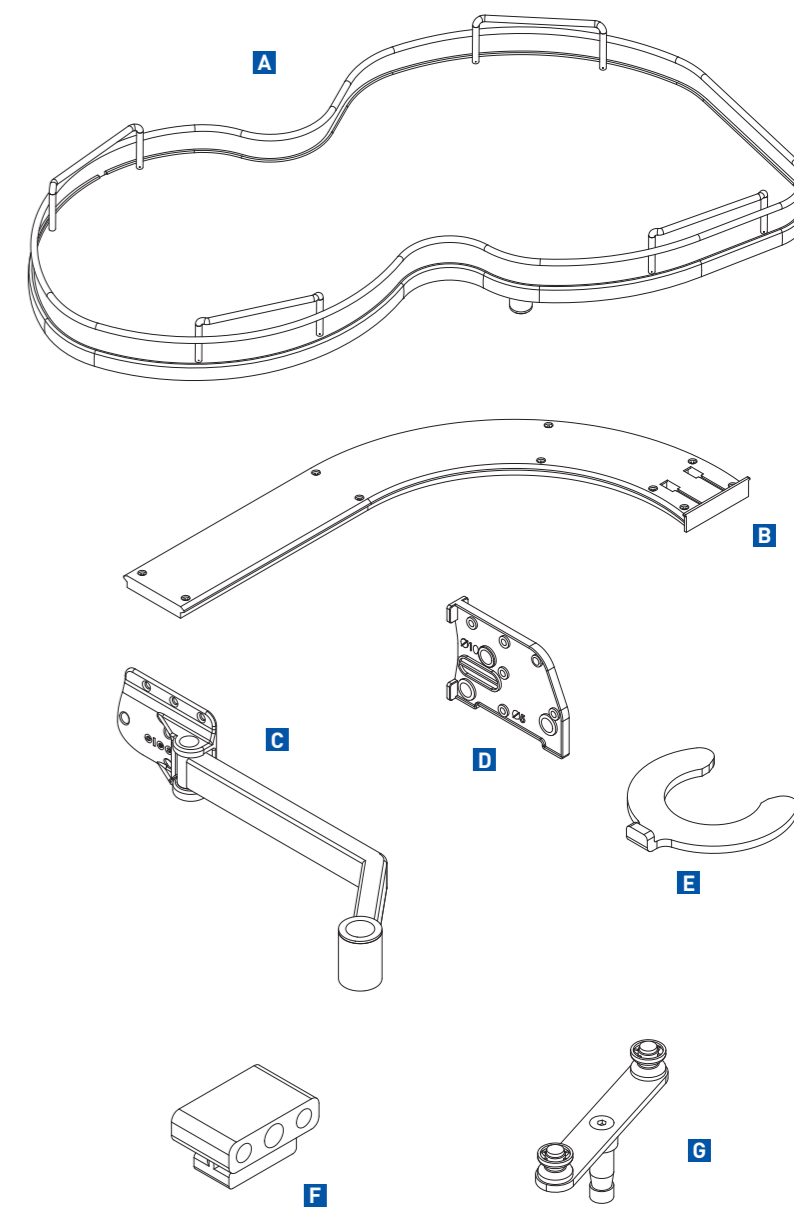

Art Nuvola 371

Ripiani estraibili per angolo base • Pull-out shelves for corner cabinet
 Étagères extractibles pour angle de base

montaggio versione dx • assembly right version
 montage version droite

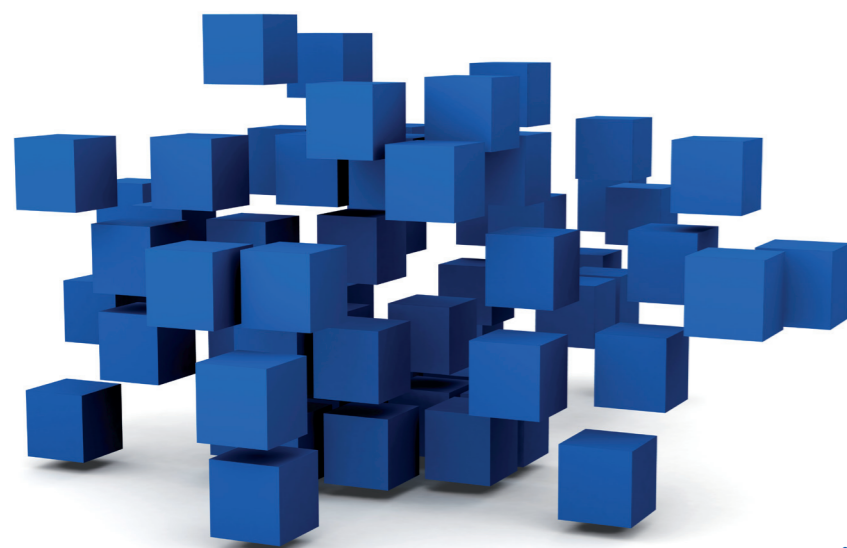

Rev.00 2012

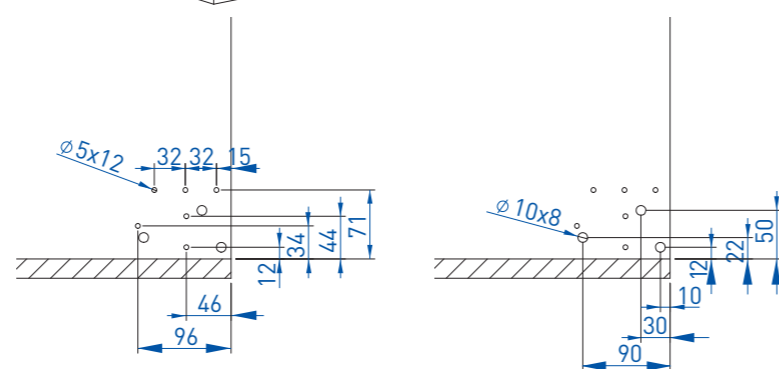
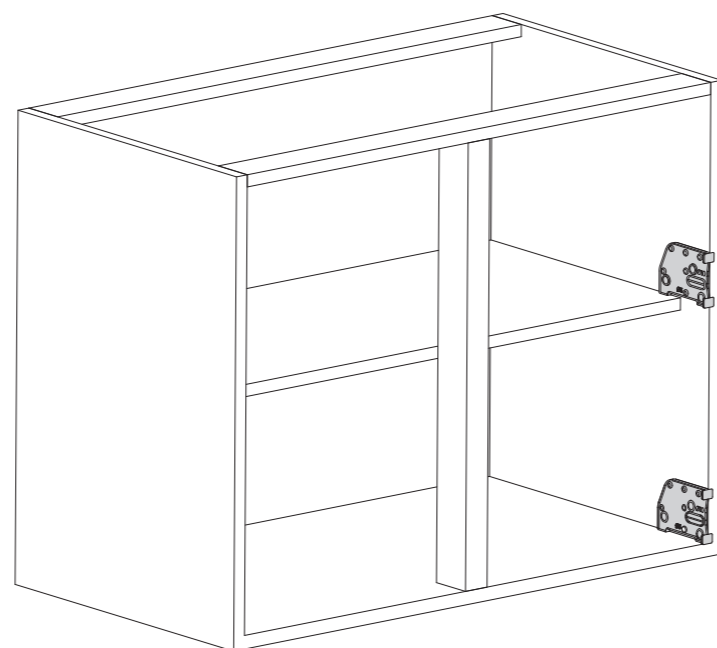

1

Effettuare la preforatura sul fianco del mobile utilizzando l'apposita dima D o rispettando le quote.
 Pre-drill the side cabinet using the relative template D or respecting the measures.
 Effectuer pré-perçage du côté du meuble en utilisant le modèle fournis D ou les dimensions.

Fissare i meccanismi C sul mobile utilizzando le euroviti in dotazione.
 Fix the mechanisms C on the cabinet side using the euroscrew provided.
 Fixer les mécanismes C sur le meuble en utilisant les eurovis fournies.

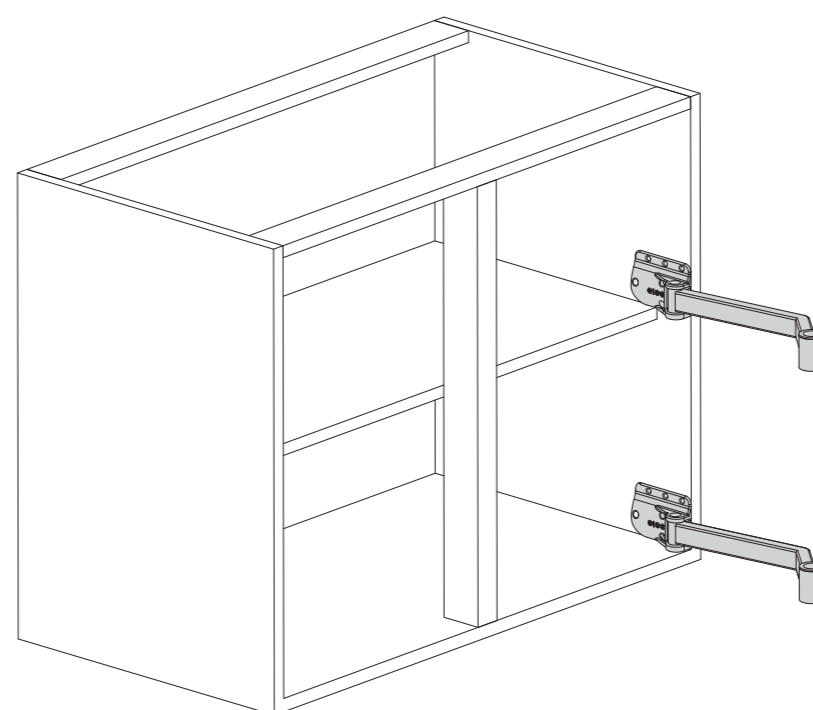

2

Segnare la posizione dei fori utilizzando l'apposita dima o rispettando le quote.
 Mark the position of the holes using the template provided or respecting the distances.
 Marquer la position des trous à l'aide du gabarit fourni ou respectant les dimensions.

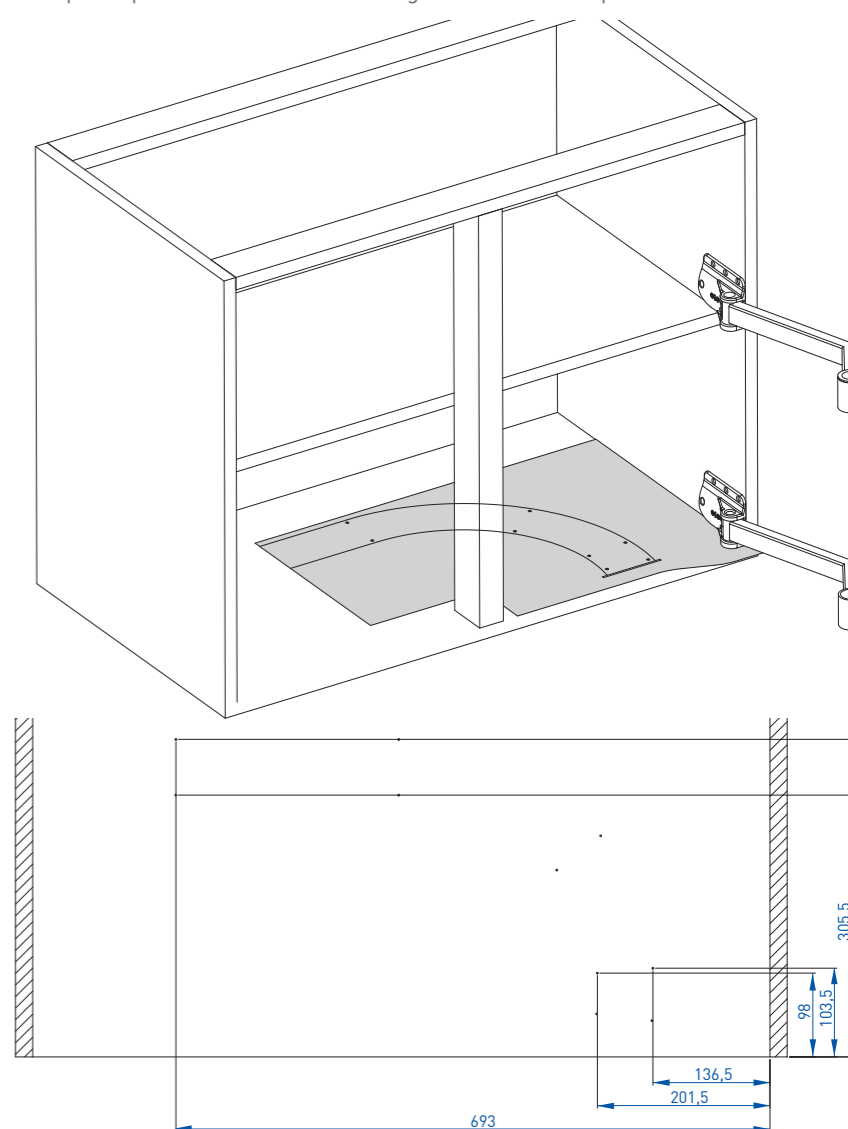

3



Tecnologia e design
Technology and design



Attenzione per la qualità
Attention for quality



Prodotto esclusivo e brevettato Sige
Sige exclusive and patented product

4

Fissare le guide in plastica B seguendo la foratura precedentemente segnata.
Fix the plastic slides B according to the holes previously marked.
Fixer les glissières en plastique B le long des trous précédemment marqués.

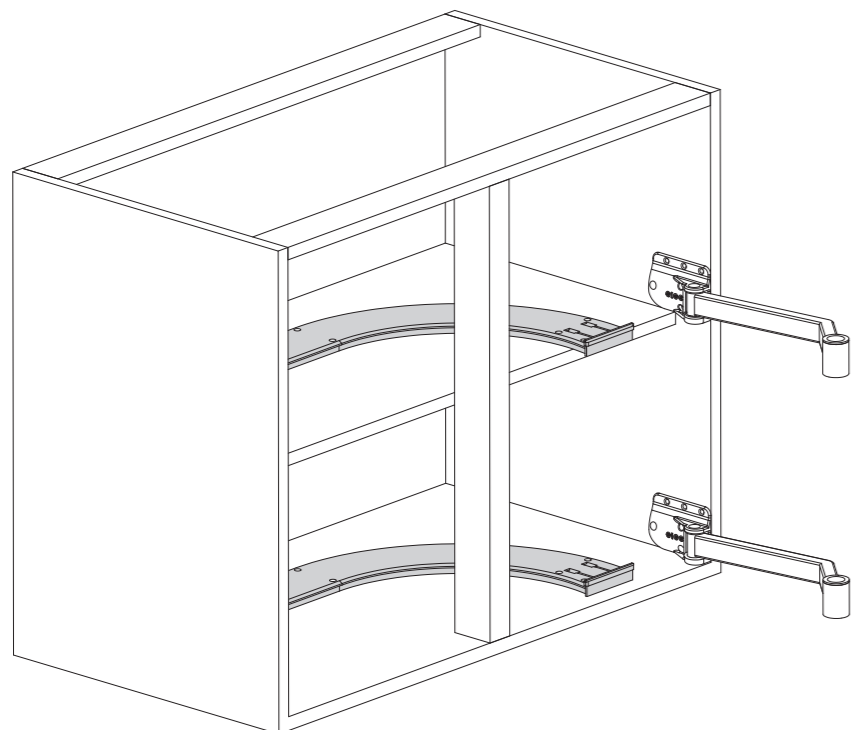

5

Montare i supporti rotanti G nelle guide in plastica B.
Insert the pivoting guides G into plastic slides B.
Monter le soutien par support G dans les glissières en plastique

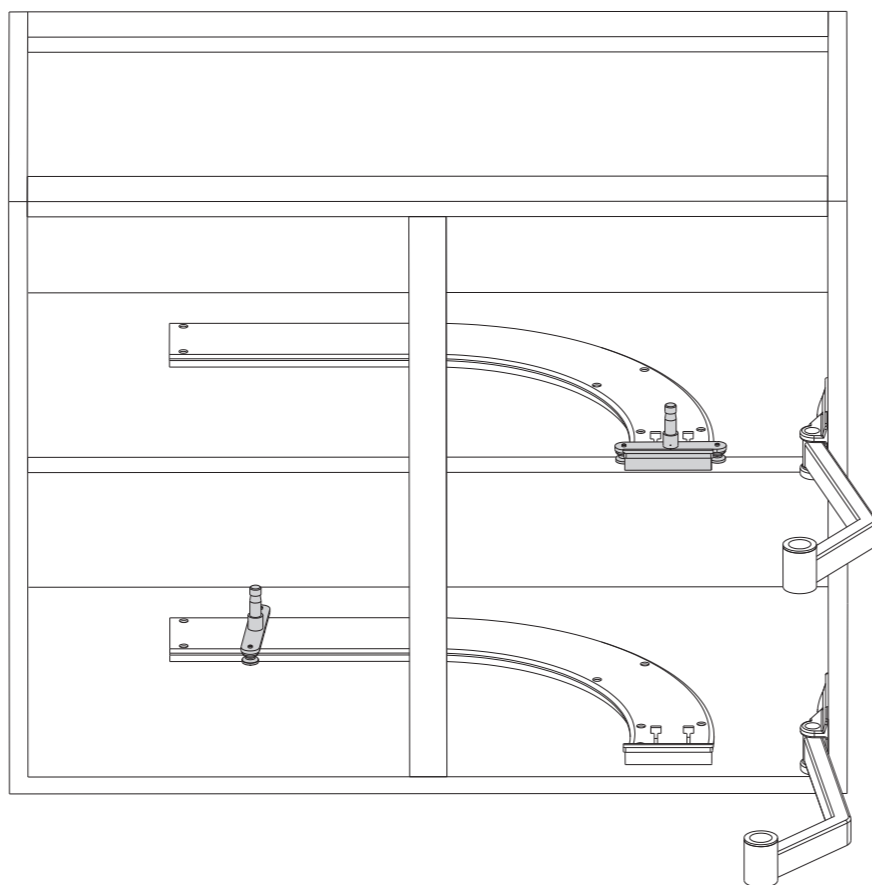

6

Inserire il ripiano nel meccanismo seguendo la sequenza e montare il particolare di sicurezza ripiano E.
Insert the shelf into the mechanism following the pictures and fasten E shelf safety ring.
Insérer le étagère dans le mécanisme selon le dessin et monter l'anneau de sécurité étagère E.

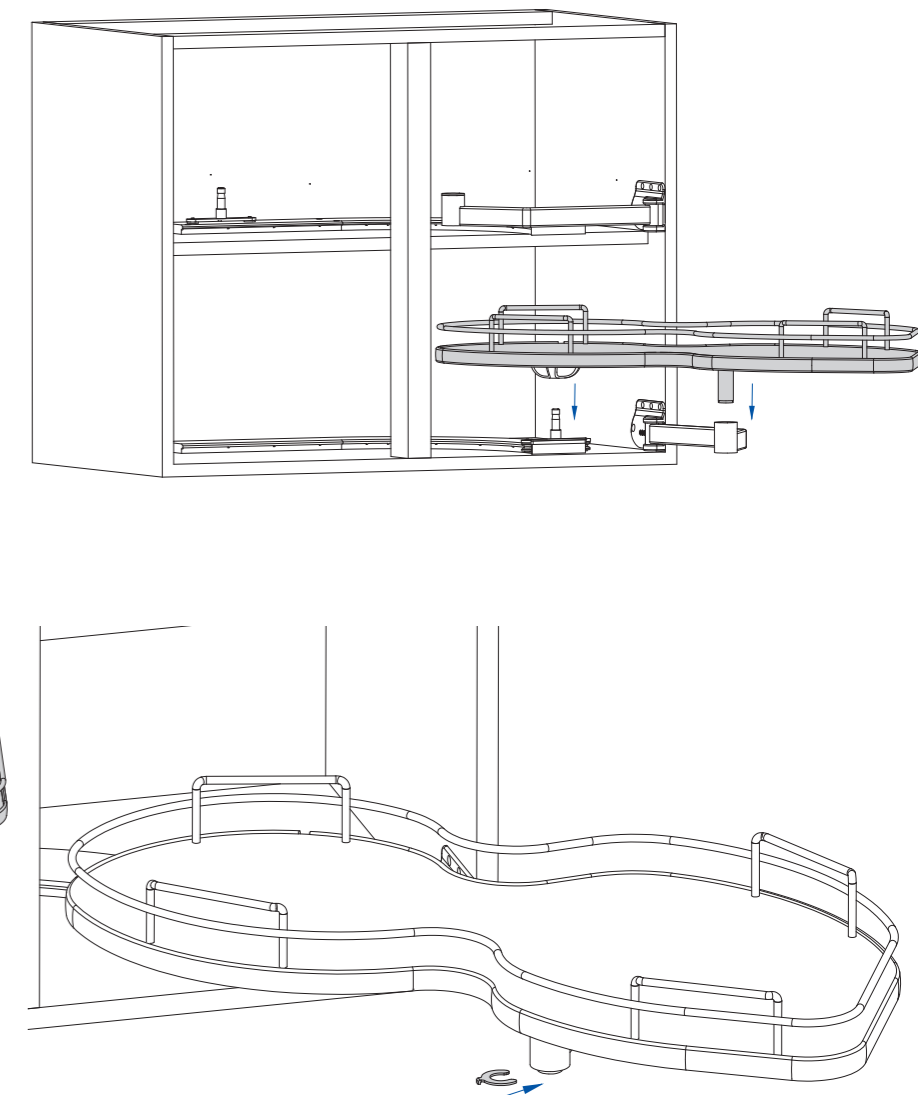
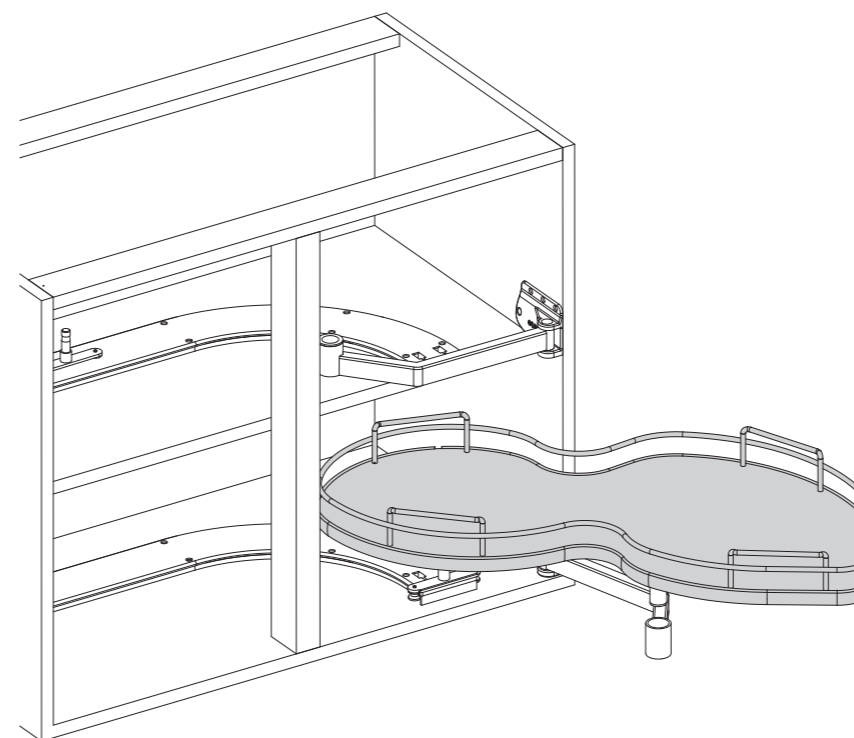

6

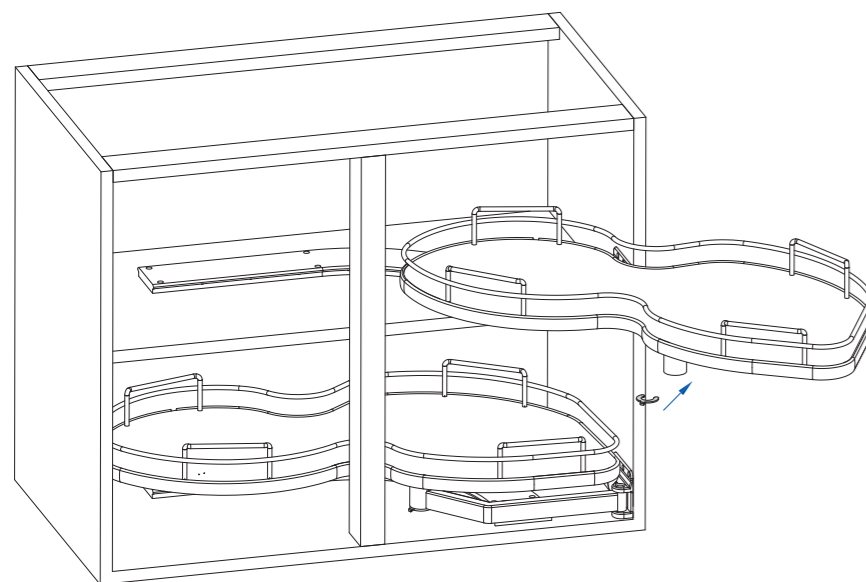
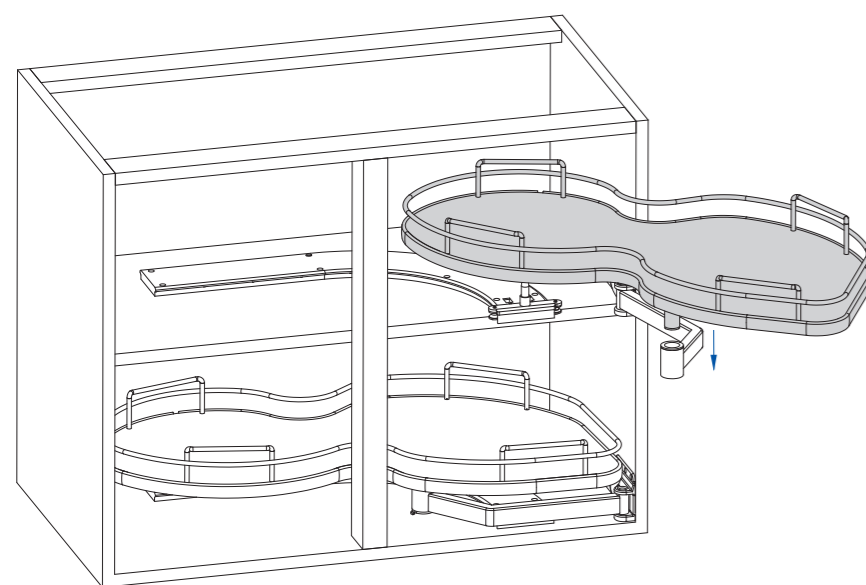

REGOLAZIONE N°1
ADJUSTMENT N°1
REGULATION N°1

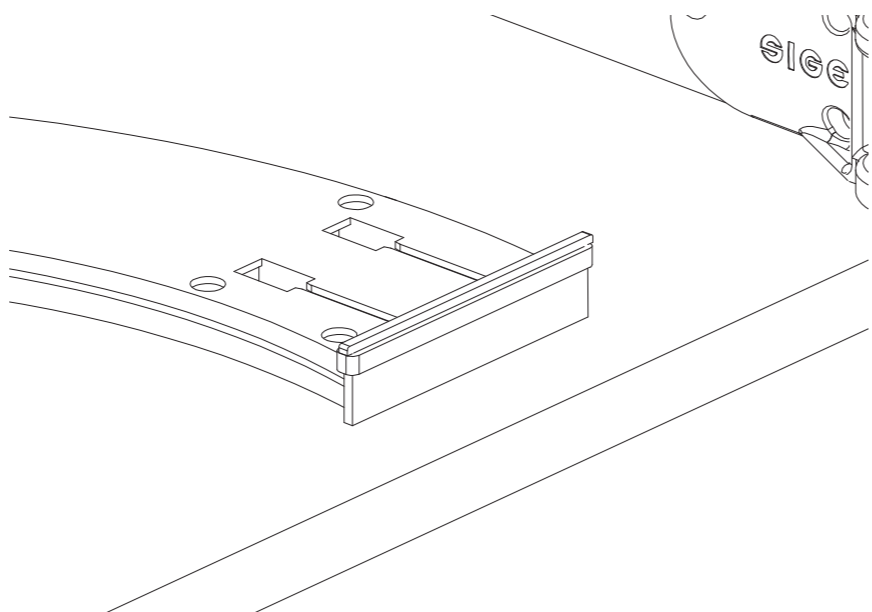
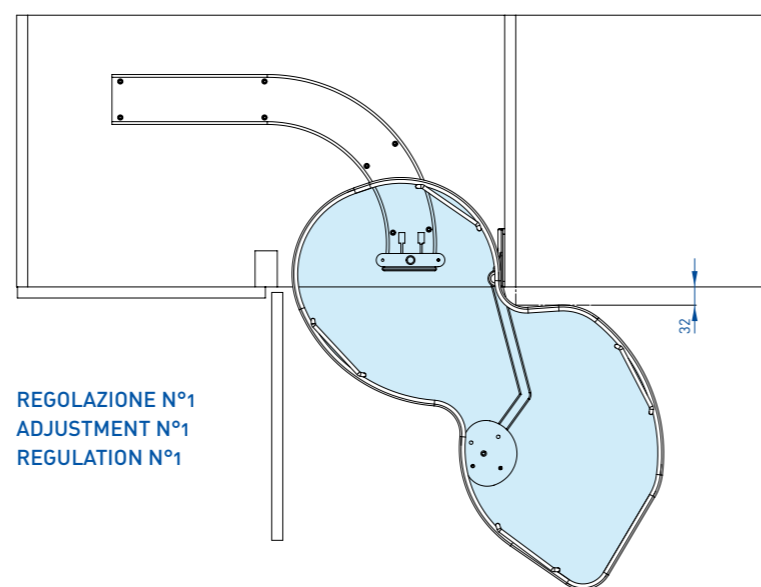

REGOLAZIONE DELL'APERTURA REGULATION OF OPENING - RÉGULATION DE L'OUVERTURE

Inserire nelle apposite scanalature i gommini fermacorsa F per regolare l'apertura del vassoio.
Insert the rubber stopper F into the slots to regulate the opening of the tray.
Introduire les caches en caoutchouc dans les gorges F pour régler l'ouverture du plateau.

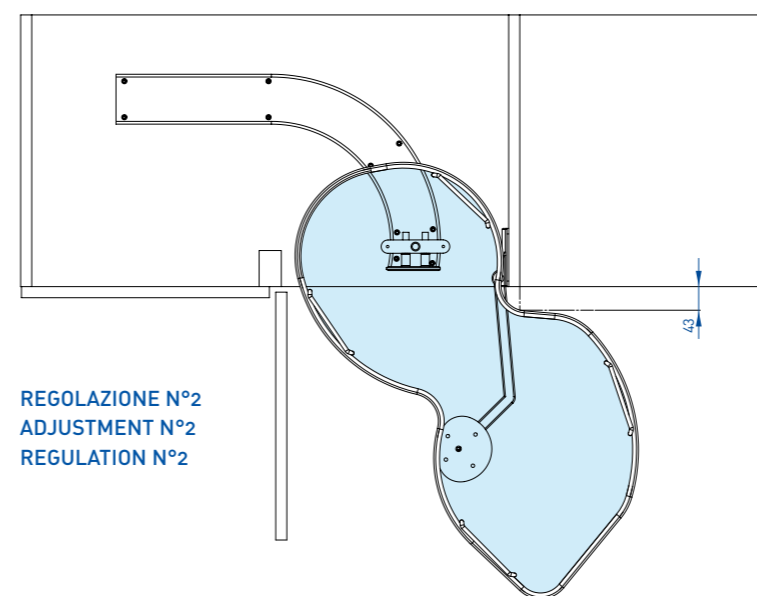

REGOLAZIONE N°2
ADJUSTMENT N°2
REGULATION N°2

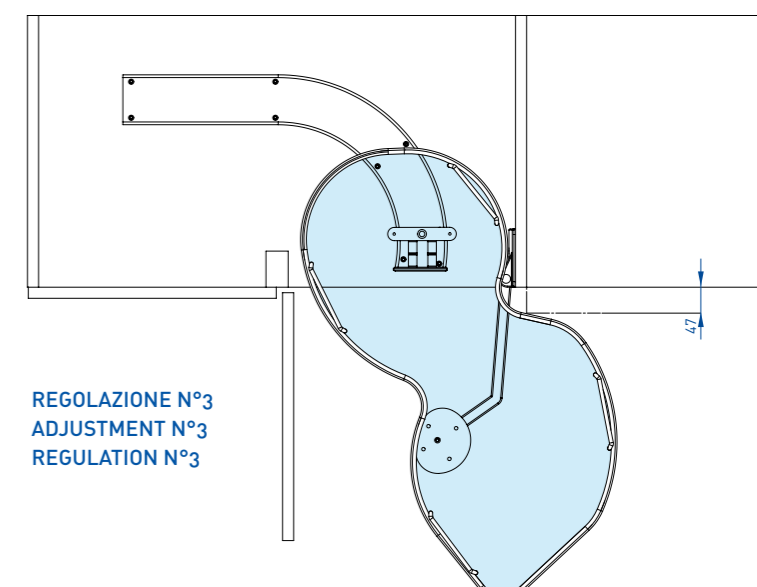
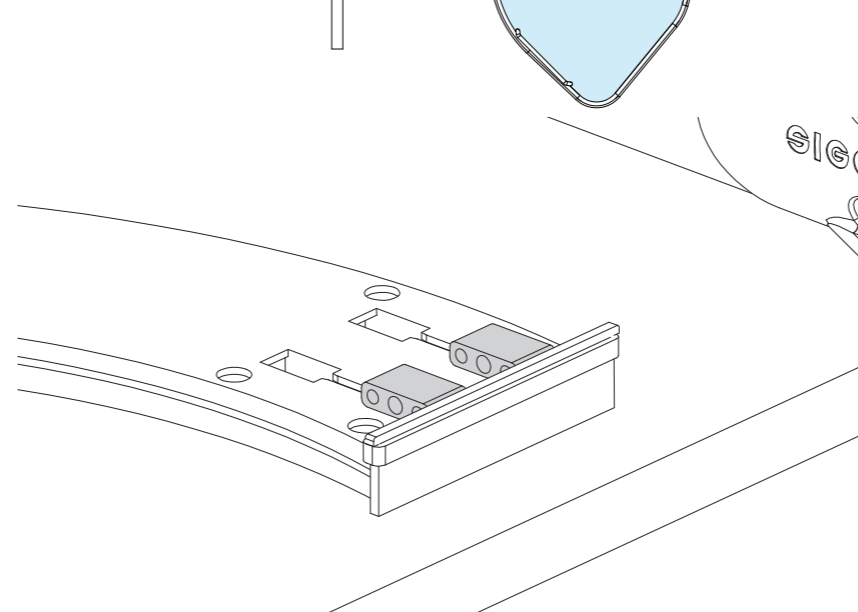

REGOLAZIONE N°3
ADJUSTMENT N°3
REGULATION N°3

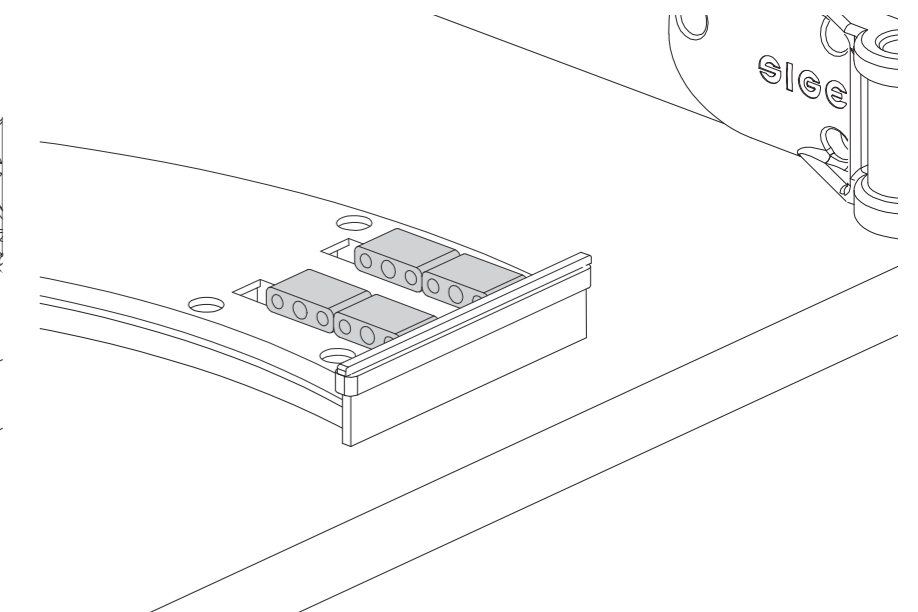

7