

# Šablony pre TARGET J10-J12

www.nabytkar.com

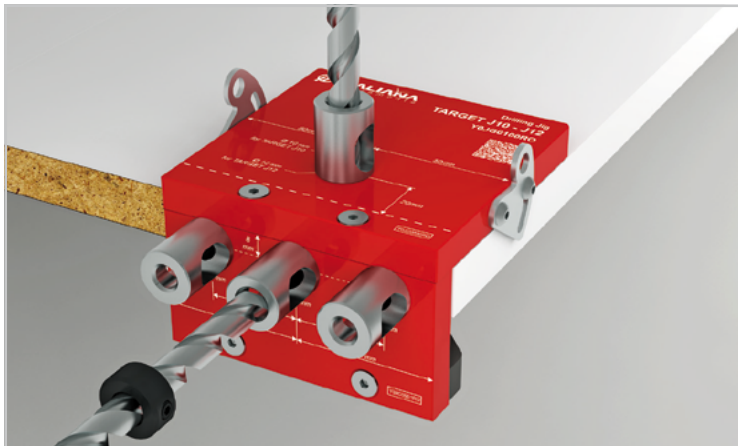

kód  
**788437**

16 - 30 mm

## GENERAL SPECIFICATIONS

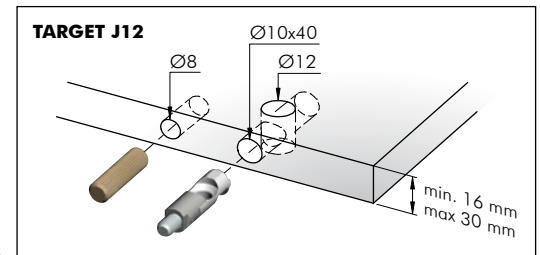
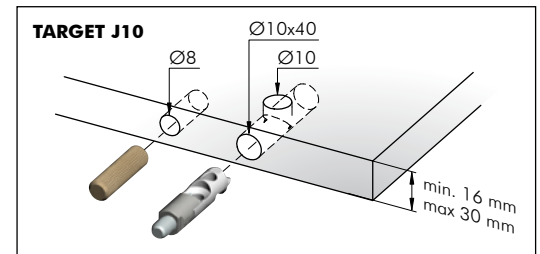
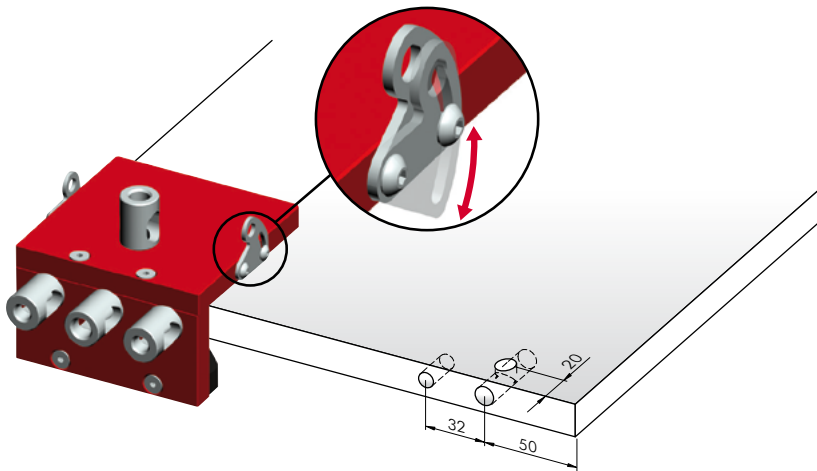

## APPLICATION OPTIONS

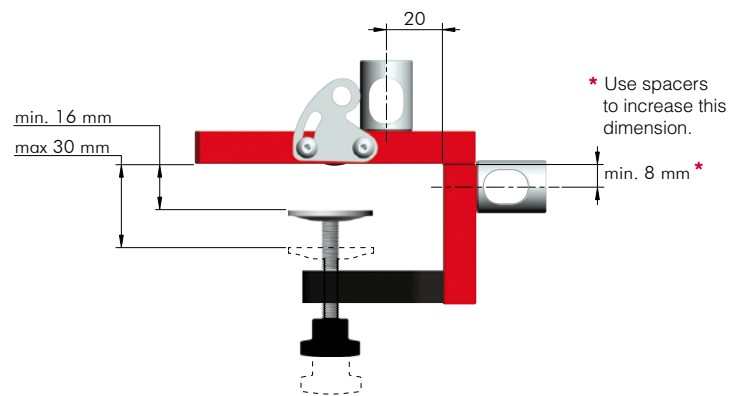
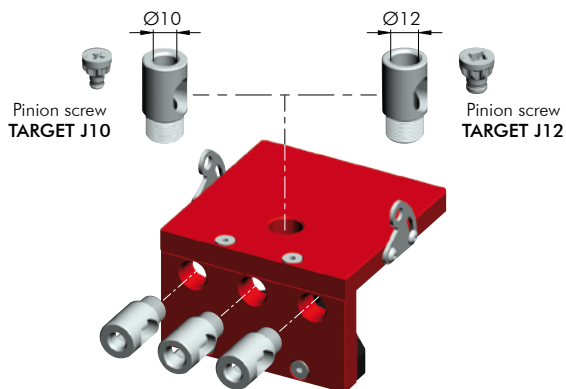

## DRILLING SPACERS FOR OTHER PANEL THICKNESSES

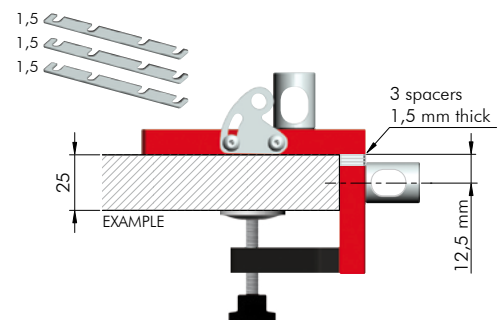
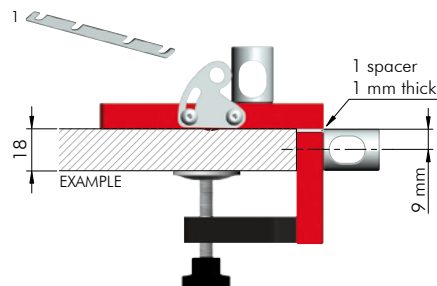
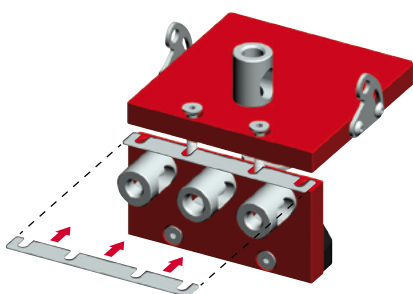

# Šablony pre TARGET J10-J12

www.nabytkar.com



kód  
**788446**

16 - 30 mm 

## GENERAL SPECIFICATIONS

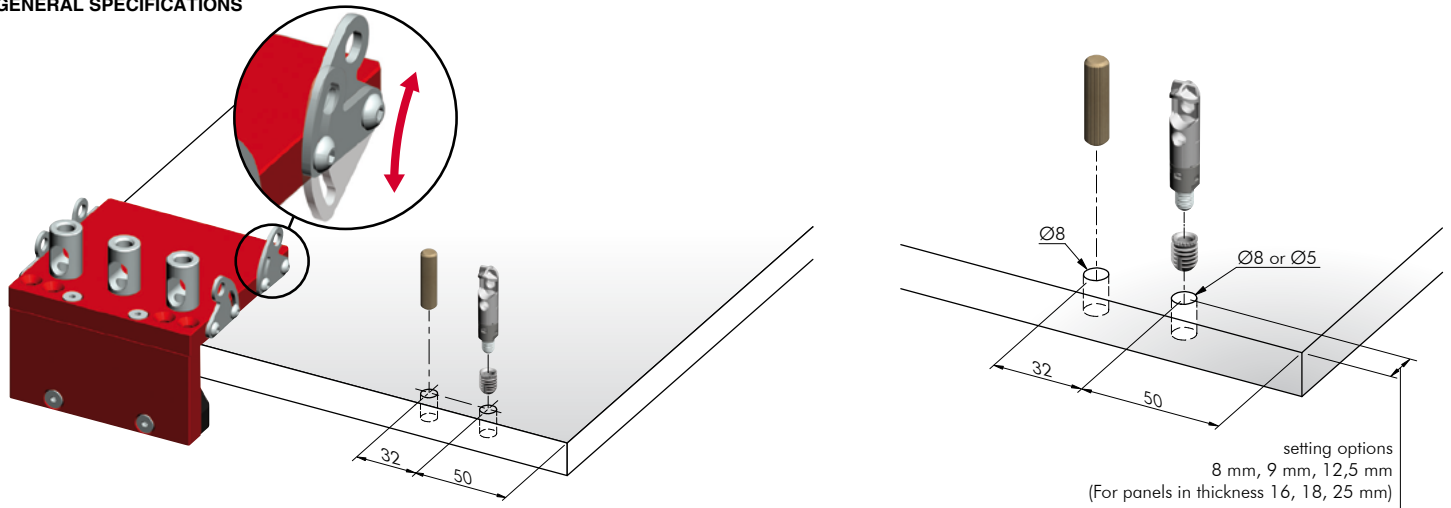

## APPLICATION OPTIONS

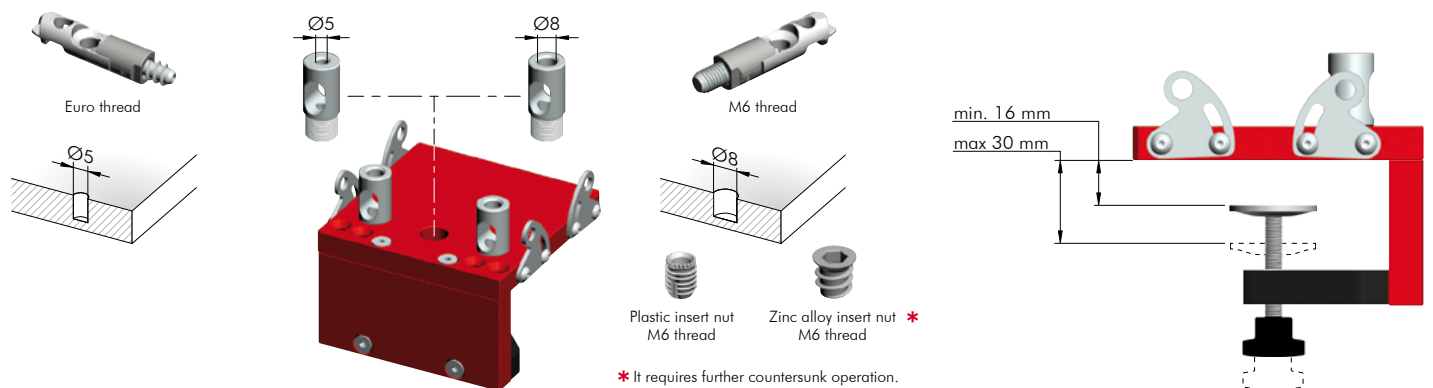
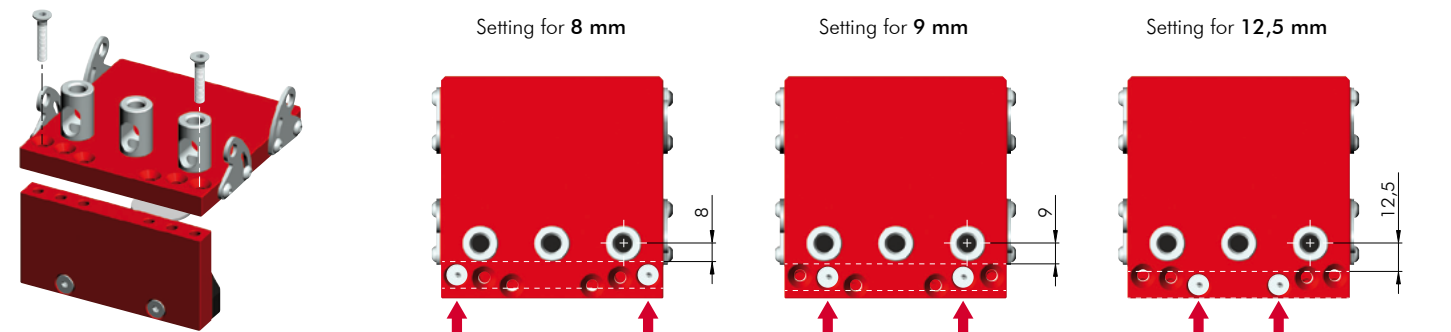

# Šablony pre TARGET J10-J12

www.nabytkar.com

## SETTING FOR ALTERNATIVE POSITIONS OF BOTTOM PANELS AND FIXED SHELVES

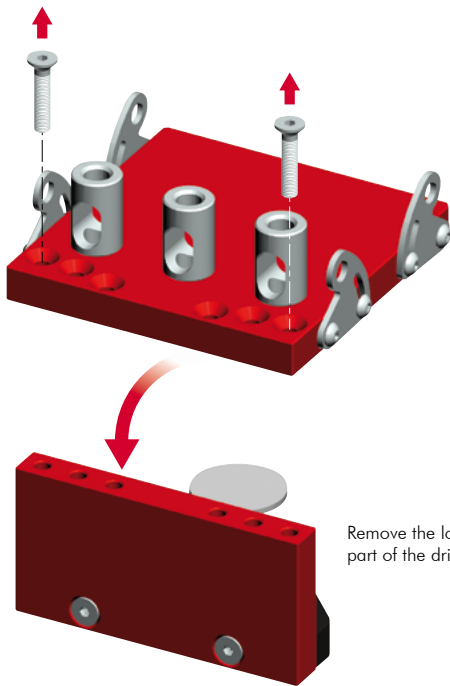

Remove the lower part of the drilling jig.

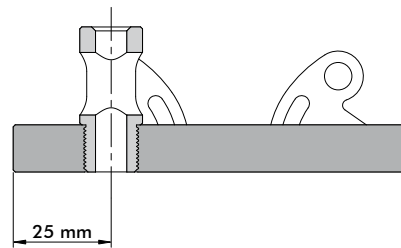
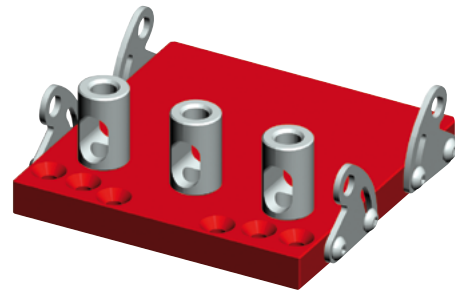

## DRILLING JIG POSITIONING

