

### Miesto vrtania

- \* Hĺbka vrtania 5 mm
- \*\* Alternatívny vrtaný otvor

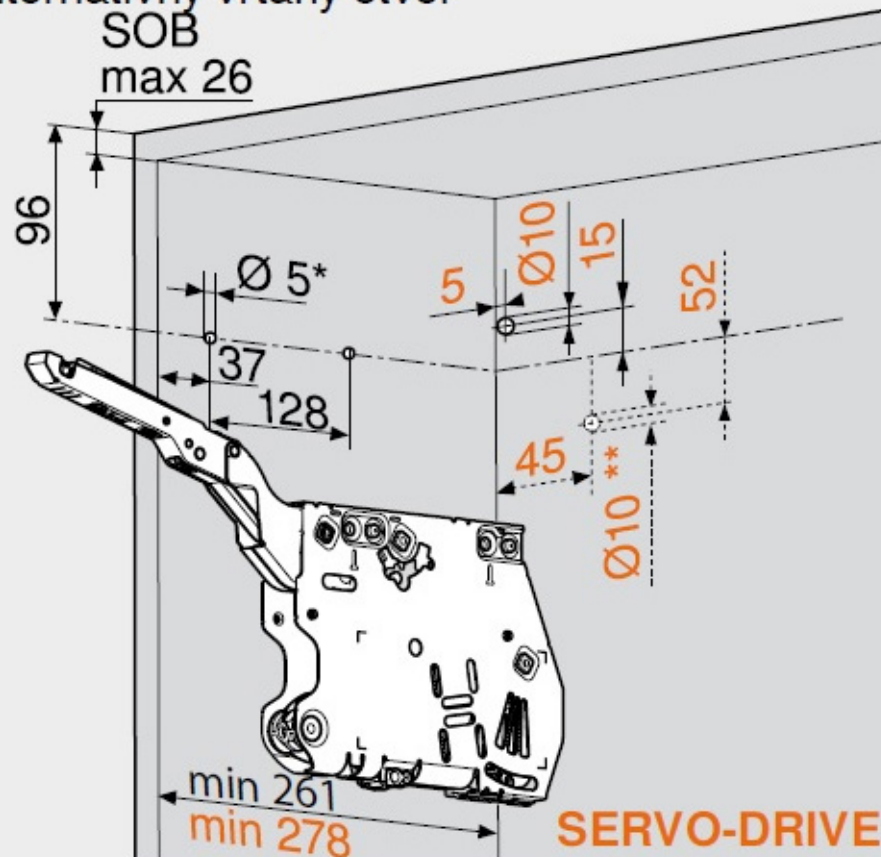

### Potreba miesta

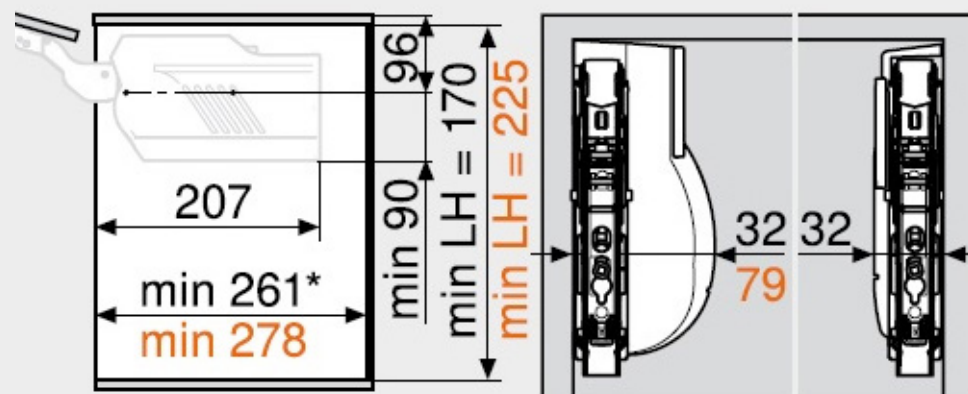

### **SERVO-DRIVE**

Spracovanie čela – drevené čelá a široké hliníkové rámy

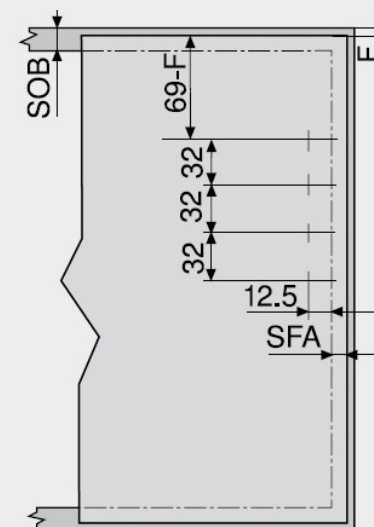

## Spracovanie čela – úzke hliníkové rámy

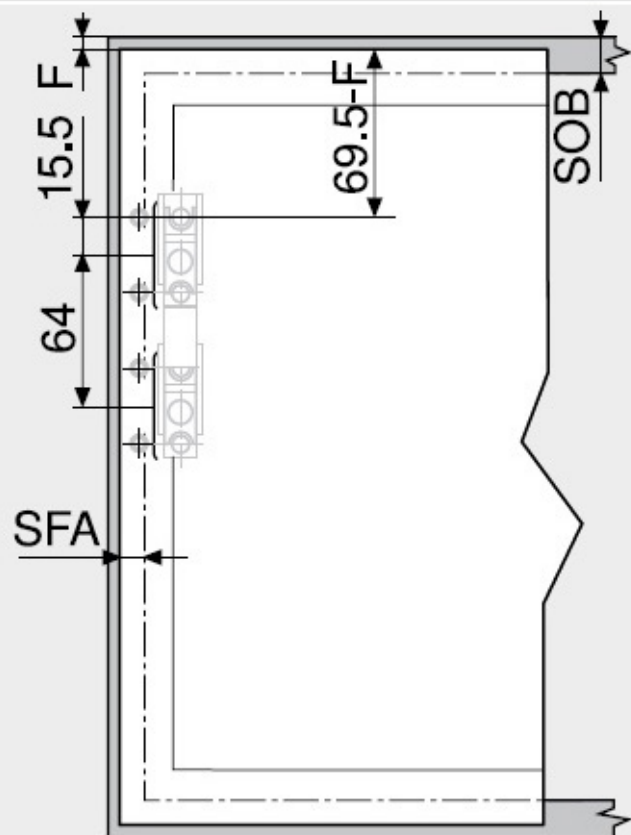

## Projektovanie – úzke hliníkové rámy

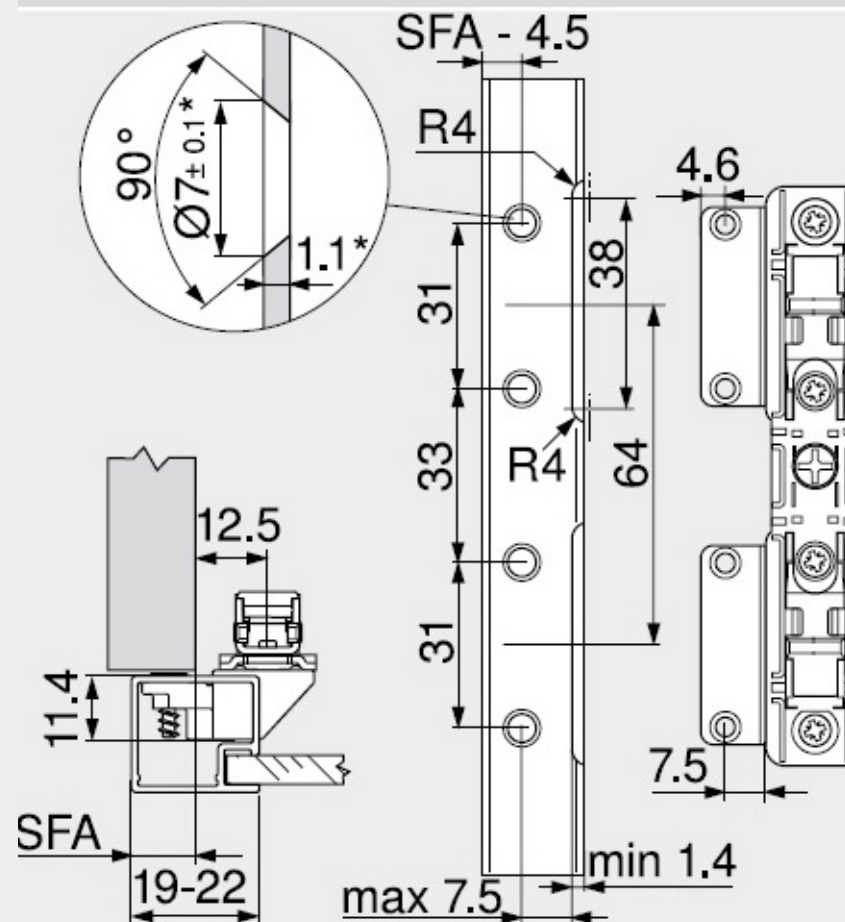

### Minimálna medzera

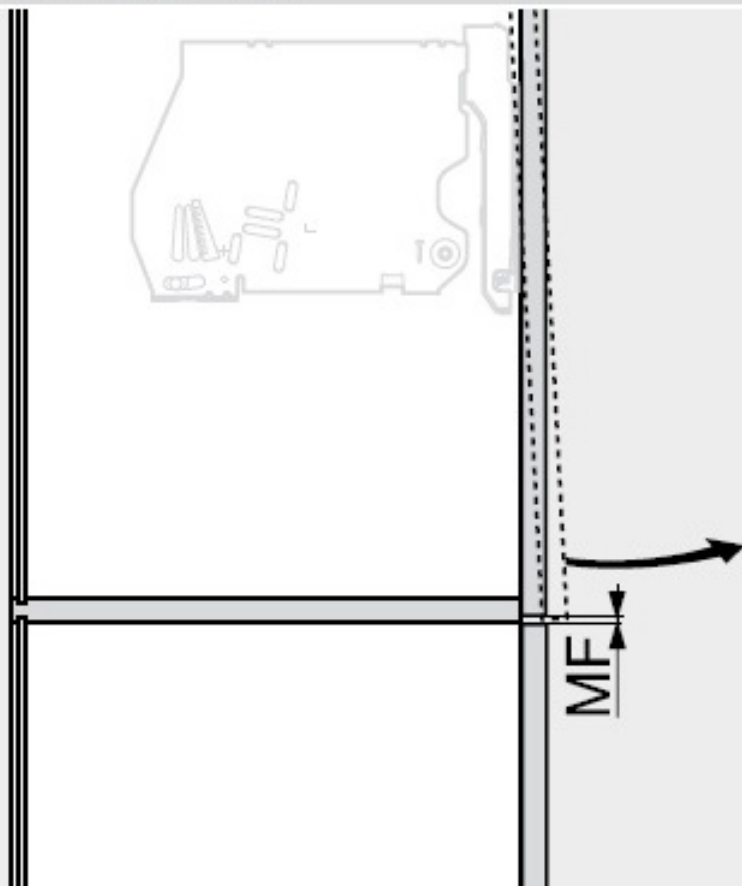

### Potreba miesta – obvodová lišta/rampa

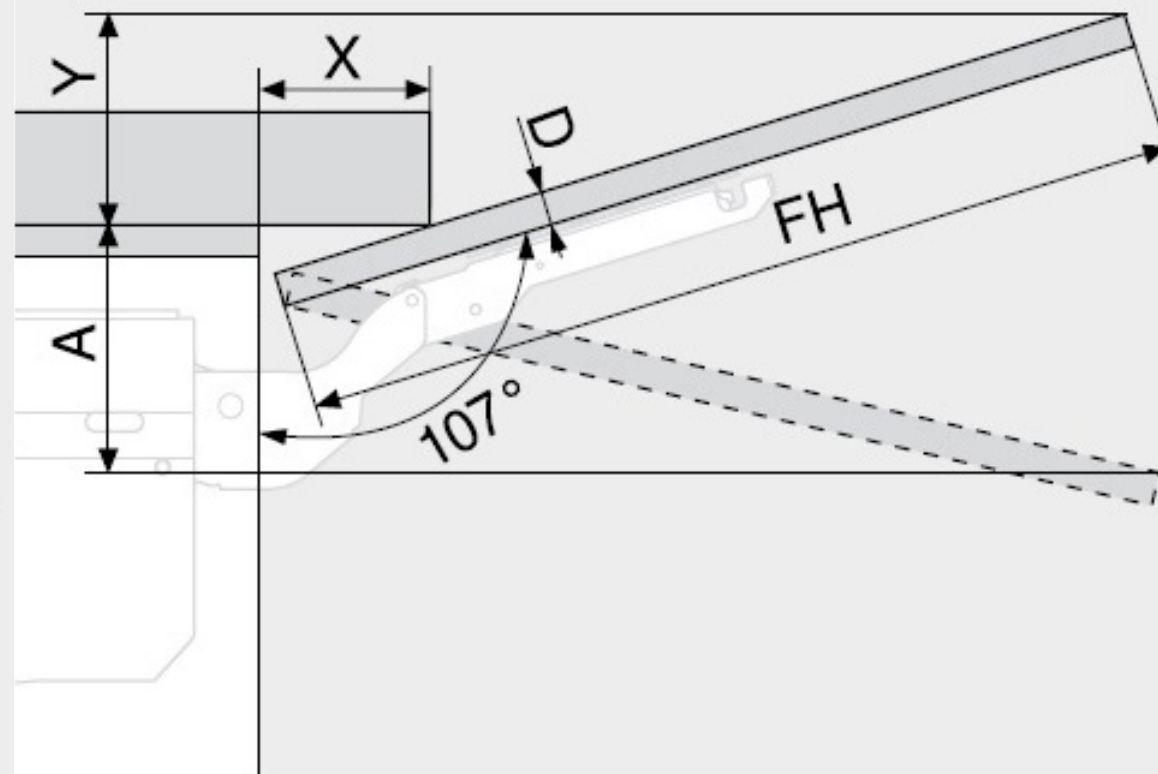

Obmedzovač uhla otvorenia		Potreba miesta (mm)			
Nie		$Y = FH \times 0.29 - 15 + D$			
100°		$Y = FH \times 0.17 - 15 + D$			
75°		$A = FH \times 0.26 + 15 - D$			
<b>D (mm)</b>	16	19	22	26	28
<b>X (mm)</b>	70	59	49	35	26